

DECWARE

Select Zen Triode Stereo Amplifier



Model SE84CS

DECWARE / *High Fidelity Engineering Co.*

1202 N.E. Adams Street Peoria IL 61603 USA
309-671-2428 Fax 309-672-1060 e-mail: fidelity@decware.com
www.decware.com (C)2000 All Rights Reserved



Owner's Manual

GETTING STARTED

Save your shipping carton. It has been designed to withstand the abuse of UPS. We tested it by dropping amps off the roof of our facility onto the parking lot. The fact that your amp is perfect condition is testimony that shipping carton works. Should you ever need to send your amp back for warranty repairs, or trade it in on something else, you will NEED the original shipping carton.

TUBES

Your amp comes with premium tubes. The output tubes are from SVETLANA and are made in St. Petersburg, Russia. These special tubes were originally designed for video applications in the Russian military. Because of this, they have much wider bandwidth than common audio tubes. The output tubes that come with your amplifier are factory matched and should last between 4 months and 2 years depending on the sensitivity of your speakers and how often you clip the amp. The input tube (smallest one) can be either a 6N1P, a 6DJ8, or a 6922. Each effect a different signature so it is nice to collect all three for experimentation. Any 5U4 rectifier will work (largest tube) and the popular 6BQ5/EL84 output tubes can be used in place of the SV83 output tubes as a direct plug-in replacement.

Look at the photo on the front of this manual to see which tubes go where.

Now that you know which tubes do what, carefully install them into the amplifier. The rectifier (5U4) should last for many years. If your amplifier was shipped with a Chinese 5U4 you will notice a small flash inside the tube when you first turn on the amp, and you will hear a mechanical vibration inside the tube as it resonates with 60 cycle ac. This causes no harm to the amplifier and is no cause for alarm. Most 5U4 tubes (especially new old stock USA made tubes) do not do this, but of the current manufactured 5U4 tubes available, we feel the Chinese is one of the better sounding.

BEFORE POWERING UP

Be sure that you always have speakers connected to this or any tube amp before turning it on. Tube amps are typically the opposite of solid state in that you can short the speaker wires

DECWARE / *High Fidelity Engineering Co.*

1202 N.E. Adams Street Peoria IL 61603 USA
309-671-2428 Fax 309-672-1060 e-mail: fidelity@decware.com
www.decware.com (C)2000 All Rights Reserved



Owner's Manual

together and nothing bad will happen.

With your speakers and line level source connected, you can turn the amplifier on by flipping the switch on the rear. The switch on the front is not the power switch, but rather a bias adjustment for the input tube. It may be operated in either position, but should be changed only when the amplifier is turned off.

After allowing the amplifier to warm up for a few minutes, you can slowly raise the volume (also located on the rear) to the desired listening level.

DURING OPERATION

After about 30 minutes you will notice the amplifier getting very warm. This is intentional, the higher temperatures brought on by the pure class A operation push the fidelity higher. Some areas of the chassis may be hotter than others. This is normal. However, proper ventilation is recommended. If you operate the amplifier inside a cabinet, allow a minimum of 4 inches on the sides, and 10 inches above if possible.

The output tubes have a glass temperature of 200 degrees centigrade by design, and you can be assured that they will be that hot if you touch them or your cat decides to lick one.

This is important to consider with the rather extremist option of front input jacks. Naturally if you use these jacks, routing of your interconnects is important. If they touch the output tubes, they will surely melt, unless of course you have our silver/Teflon cables that will not melt.

The last heat related comment is this - turn your amp off when your not using it. Tube life is directly tied to hours of operation so there is no point wasting it when your not listening.

INITIAL BREAK-IN EXPERIENCE

Unfortunately the esoteric parts in this SELECT amplifier besides being extremely fast, also need to break-in. The combination of a fast amplifier and fresh parts can be a little rude so we will explain the process.

Specifically it is the exotic capacitors that actually require the burn-in to sound right. The fastest way to achieve a burn-in is to play the amplifier for 5 hours and then turn it off and let it rest for

DECWARE / *High Fidelity Engineering Co.*

1202 N.E. Adams Street Peoria IL 61603 USA
309-671-2428 Fax 309-672-1060 e-mail: fidelity@decware.com
www.decware.com (C)2000 All Rights Reserved



Owner's Manual

at least 5 hours.

Once you have repeated this process 5 times your soundstage will bloom and the focus will lock into a crystal clear image.

If you listen to your amp during the burn-in process this is what you will experience: First the amp will sound good followed by almost an immediate increase in harshness which after 30 minutes will change to dullness and continue to go back and forth. During this mind bending experience, the imaging and soundstage will be unstable and somewhat restricted.

There will be moments of incredible sound during this process and equally ugly sound. You will know when the amp is burned-in because out of nowhere some night when your listening the amp will bloom with a soundstage almost double in size and forever stay that way in all successive listening sessions. As you amplifier ages, it will season like fine wine and continue to do so for many years.

DESIGN GOAL

The design goal behind this amplifier was simply to take our stock Zen Triode amp and push the envelope of its design to the limit. It uses all the same parts as found in our Signature Mono Blocks (model SV83S) and is every bit the equal in fidelity when power is not an issue. Perhaps the purist amp in the world you will likely never find it to be the weak link in your audio system. Since you only hear the weakest link in a high end audio system, you will find the quality of your source and cables as well as your speakers to effect profound changes in the overall fidelity of your system.

Like the stock Zen amp, this is intended for those who like to get lost in a huge 3-D image and experience the emotional side of music that only this type of resolution can accurately convey without grain or ear fatigue. It is not intended for loud playback levels, or parties. Unless of course you have full range horn speakers around 100dB efficiency in which case you can have both. We recommend 4 ohm speakers with simple crossovers that are in excess of 90dB for most listening. This amplifier will run speakers down to less than 1 ohm, and put out more power as it does so. Therefor you need not be concerned about dips in your impedance curve when choosing a speaker.

DECWARE / *High Fidelity Engineering Co.*

1202 N.E. Adams Street Peoria IL 61603 USA
309-671-2428 Fax 309-672-1060 e-mail: fidelity@decware.com
www.decware.com (C)2000 All Rights Reserved



Owner's Manual

CIRCUIT DESIGN

The Zen amp is a combination of simple yet unique circuit design, high quality parts selected for their signature, intense quality control, and layout.

The small size makes possible the art of hand soldering the entire circuit with only parts leads and no hook-up wire. The ground buss is silver and so are the cathode leads. The power supply is significantly over sized and breaths naturally with the music while holding steady to less than a 0.05 millivolt tolerance at full clipping.

There are only 11 solder points between the input and output jacks of this amplifier making it actually simpler than a solid state Op-amp. Output transformers were meticulously designed and hand built for this amplifier, as is the power transformer.

These features combine to create a unique and magical amplifier that will sound better than anything in its power range.

The small size makes possible the art of hand soldering the entire circuit with only parts leads and no hook-up wire. The ground buss is silver and so are the cathode leads. The power supply is significantly over sized and breaths naturally with the music while holding steady to less than a 0.05 millivolt tolerance at full clipping.

There are only 11 solder points between the input and output jacks of this amplifier making it actually simpler than a solid state Op-amp. Output transformers were meticulously designed and hand built for this amplifier, as is the power transformer.

These features combine to create a unique and magical amplifier that will sound better than anything in its power range.

On the follow page is a picture of what your amplifier looks like under the hood (minus the shipping block between the transformers).

DECWARE / *High Fidelity Engineering Co.*

1202 N.E. Adams Street Peoria IL 61603 USA
309-671-2428 Fax 309-672-1060 e-mail: fidelity@decware.com
www.decware.com (C)2000 All Rights Reserved

DECWARE

Owner's Manual

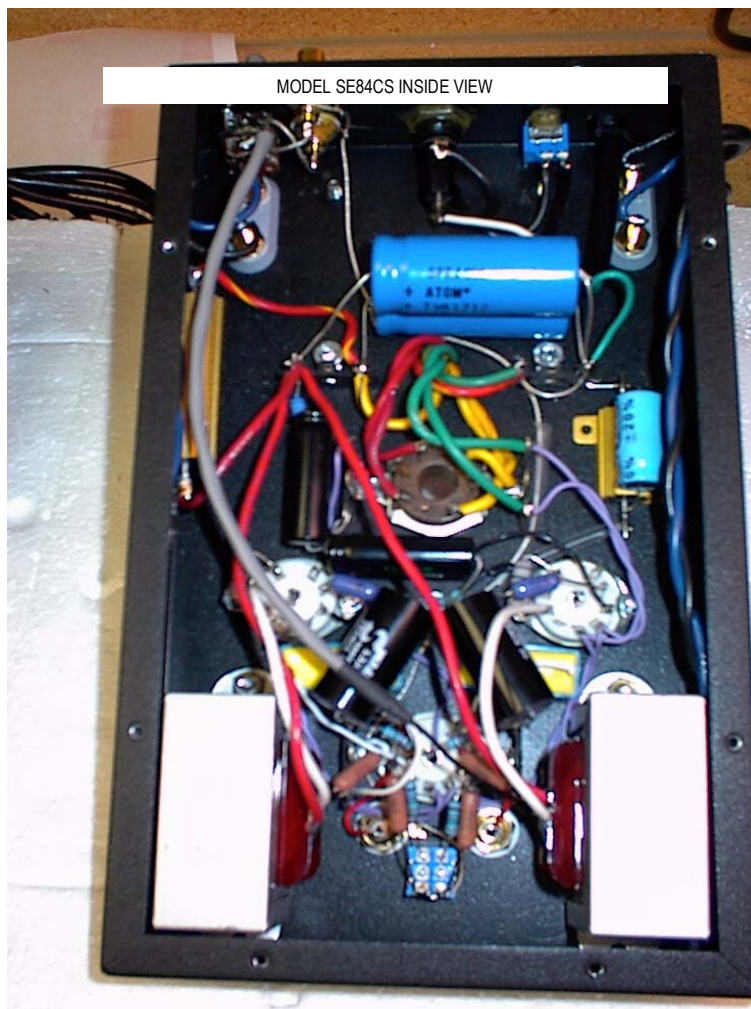

DECWARE / *High Fidelity Engineering Co.*

1202 N.E. Adams Street Peoria IL 61603 USA
309-671-2428 Fax 309-672-1060 e-mail: fidelity@decware.com
www.decware.com (C)2000 All Rights Reserved



Owner's Manual

INPUT OPTIONS

This amplifier features input jacks on the rear with a rear mounted ALPs volume control so that you can use it without a preamp. Using a good pair of interconnects directly from the outputs of your CD player or DAC will clearly demonstrate how bad most preamps really are.

The front jacks on this amplifier are for the purist who wants the most direct connection possible. Many people spend hundreds and sometimes thousands of dollars on interconnects only to plug them into an amp that uses by comparison a far less expensive wire from the input jack to the first gain stage. Imagine having a \$500 cable and soldering a foot or two of 30 cent per foot beldon wire on the end?

Using the front jacks, your cables hook directly to the control grid of the input tube with no resistors in the circuit. In fact the only thing between the input jack and the control grid of the input tube is a one inch piece of silver/Teflon wire. Using these jacks the volume control on the rear becomes a partial shunt to ground and is completely removed from the signal path. The volume control will still act to change the volume with a limited range. You will not be able to turn the volume all the way down in this configuration because the pot is lifted with a 1000 ohm resistor from ground to prevent shorting the outputs of your source and potentially causing damage.

BIASING

One of the hallmarks of this amplifier like the stock Zen amp, is the bias switch on the front. In the back position, the input tube is biased harder creating a larger voltage swing. This adds gain, dynamics, presence. In the forward position, the input tube is biased a little more conservatively yielding a more laid back and neutral presentation. Which one will sound better is purely subjective and we encourage you to experiment. Even though we do not officially recommend changing this switch without first turning the amp off, we change it "on the fly" while listening here at the factory all the time even though there is a significant "pop" that comes through your speakers when its changed. Our feeling on this is that the amplifier being only a couple watts is not enough power to damage the tweeters in 99% of all speakers we know of.

This switch is one reason why the Zen amps can use either of the three input tubes and sound correct with all three. Fine tuning your amp can be accomplished with the combination of trying all three types of input tubes, each with the bias switch in both portions. This is six distinct different signatures, and is like having 6 different amplifiers to play with.

DECWARE / *High Fidelity Engineering Co.*

1202 N.E. Adams Street Peoria IL 61603 USA
309-671-2428 Fax 309-672-1060 e-mail: fidelity@decware.com
www.decware.com (C)2000 All Rights Reserved



Owner's Manual

BIASING CONT.

The output tubes are self biasing and self balancing making reliable performance possible even with un-matched tubes. You will never have to bias your amp, even after tube changes.

LISTENING

There is no doubt you will find the fidelity of this amplifier superior to almost anything within its power range, however many people do not experience the full potential of its spell casting abilities due to weak links in their set-up. Usually speakers and room. Because of the incredible resolution of this amplifier, you will find it easier to adjust your speakers properly for best imaging because there is no time smearing, or filtering common in most amps.

Perhaps the amp's strongest weapon is the huge soundstage it casts. To hear music get completely holographic, you need to work on room acoustics and speaker placement. Do not put your speakers near any walls, especially the front wall. Do not put reflective surfaces (TV SETS) between your speakers. Pull them out into the room several feet from the front wall and toe them in to create a triangle with your listening chair.

Take the opportunity to try different speakers whenever possible, you may find that now with a good amp the differences in speakers will be even more profound. Since you always hear the weakest link in your system, you will want to pay attention to cables and speaker wires as they too will make far more difference than you think.

Power conditioners (real ones) are recommended. Clean power is essential. To find out what clean power sounds like, listen to the amp at 2:00 a.m. when there are no harmful or nasty harmonics in the power line. Once you have your first out of body experience during a late night listening session we have a forum on our web site where you can share your experiences with other Zen Triode owners and get tips on set-ups that really work well.

USING YOUR AMP AS A MONO BLOCK

You can get another amp and bridge them into mono so that you can use one amplifier per channel for more power. Because the Zen puts out more power into lower impedance loads, bridging a pair of these amps will net you 6dB additional power before clipping. This is usually a cost effective alternative to finding more efficient speakers.

DECWARE / *High Fidelity Engineering Co.*

1202 N.E. Adams Street Peoria IL 61603 USA
309-671-2428 Fax 309-672-1060 e-mail: fidelity@decware.com
www.decware.com (C)2000 All Rights Reserved



Owner's Manual

USING YOUR AMP AS A MONO BLOCK CONT.

To bridge a Zen amp, you simply either parallel or series the outputs of the amplifier. We recommend series, which means take a positive from one channel and connect it to the negative of the other channel with a short piece of wire. The remaining two unused posts will serve your speaker.

Remember that the inputs of both channels must see a signal if the amp is bridged. To do this you can use a Y-Cable. If you decide permanent mono operation is in order we recommend you send the amp back so we can short the input jacks together, and modify the volume control to maintain the same 100K input impedance. This eliminates the need for a Y-Cable, and gives the amp more gain which is handy if you are not using a preamp.

Unlike most stereo amps, bridging a Zen does not kill the fidelity. Most people who have done so report added weight and smoothness to the presentation without loss of detail or focus. This is made possible by the floating output transformers and the series connection of the outputs.

WARRANTY

Your new amplifier is built so well that during research and development we took one and dropped it from a height of 15 feet onto concrete 40 times, followed by putting it into a paint shaker for 24 hours. Badly beaten, the amp was retubed and played perfectly with ZERO internal damage. This is why we offer you a lifetime warranty on parts and labor to the original owner. You have purchased a 100% hand made amplifier of the highest build quality in the industry. It was designed to give 30 years of trouble free service. Enjoy.

ADDITIONAL INFORMATION

and design theory can be found at our web site: **WWW.**

decware.com

DECWARE / *High Fidelity Engineering Co.*

1202 N.E. Adams Street Peoria IL 61603 USA
309-671-2428 Fax 309-672-1060 e-mail: fidelity@decware.com
www.decware.com (C)2000 All Rights Reserved

DECWARE

Owner's Manual

HELP WITH CHOOSING SPEAKERS

What the Zen amp likes is simple speakers with simple crossovers. Complex speakers with lots of components require complex crossovers that will waste much of the first watt as heat before it gets to the drivers. Zobel impedance balancing networks also complicate things causing the Zen to clip at the zobel frequency before anywhere else.

The Zen amp likes 4 ohm speakers better than 8 ohm. 16 ohm speakers are NOT recommended. It is safe to run your Zen down to 1 ohm. That means that when choosing speakers you need not worry about dips in the impedance curve of the speaker.

Efficient speakers will allow you to really hear what your Zen is capable of, as the detail and speed will increase dramatically when going from 90dB to 96dB as an example. You can usually find and get by with simple speakers that are less sensitive, but for those wanting to hear the ideal, you should consider quality designed horn speakers, and full-range drivers that require no crossovers. While not required to enjoy this amplifier, these types of high efficiency speakers can not only resolve inner detail better, but also reach pressures that would have your friends believing you have at least a 100 watt amplifier, and that is always fun.

BELOW IS A LIST OF SPEAKERS THAT RANGE FROM JUST GETTING BY TO EXCELLENT

Audio Research C3L	ESS AMT1's
Infinity Overture One's	Almost all Pro PA speakers or monitors
Some AR monitors will work	Linaeum LFX's
B&W 602's	JPO Memorial using the Anniversary Issue Diatone
ESS AMT Monitors	P610MB
JBL M5	Coincident Speaker Technology Triumph</
JBL Control 5	Paradigm MiniMonitor's
ALL KLIPSCH SPEAKERS	KEF Coda 7's or 8's
AR TSW Monitors	SYNONYME
Altec Voice of the Theater's	PSB Alpha Series - All of them KEF
RA Labs (Roy Allison) Mini Reference monitors	Q15 loudspeakers
AR M1's	JBL L300 Summits, 93db
Harbeth PL-3's	Coincident Triumph Signatures
Energy Connasseur C-6 Speakers	MB Quart D-40's
Bose 301's / 901's	Hammer Dynamics Kits
Jamo M7 mini monitors	Reynaud Twins 90dB 4 ohm
Anything made using Lowther drivers	The Horns from TheHornShoppe.com
	Coincident Triumph Signatures

DECWARE / *High Fidelity Engineering Co.*

1202 N.E. Adams Street Peoria IL 61603 USA
309-671-2428 Fax 309-672-1060 e-mail: fidelity@decware.com
www.decware.com (C)2000 All Rights Reserved

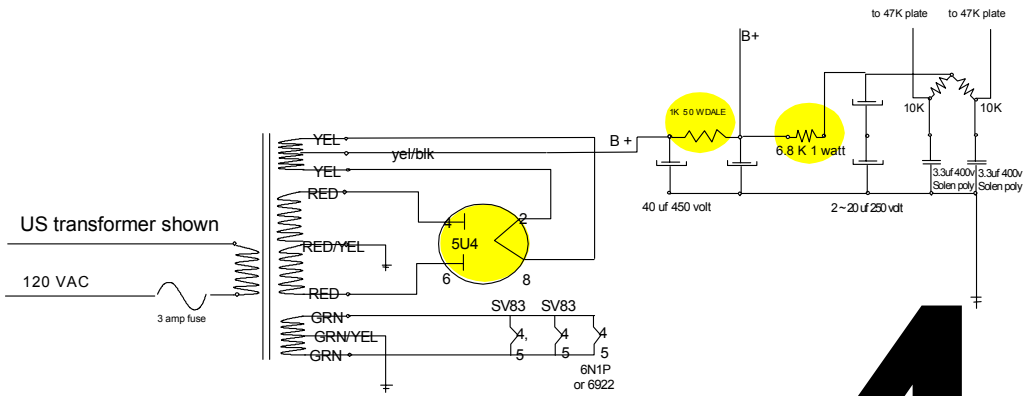

NOTE: We recommend wiring the primary for 240 volts even if your voltage is 220 or 230. Use a 3 amp fuse.

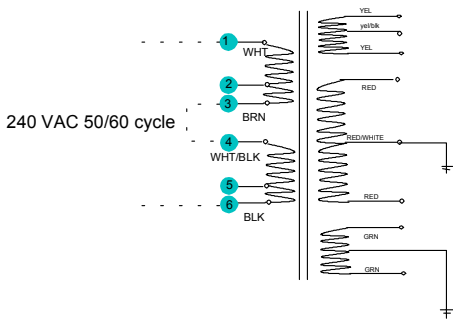

For Japan 100 volt connect 1 to 4 and 2 to 5
Use 1,4 and 2,5 for line connection.

ZEN TRIODE STEREO AMPLIFIER
MODEL SE84C-S

DECWARE
High Fidelity Engineering Co.
USA
www.decware.com

This schematic can be used to construct a Zen Triode Stereo Amplifier model SE84CS or it can be used to upgrade a model SE84C to model SE84C-S. The yellow areas indicate the upgraded parts that differ between the two.

To test your amplifier after upgrading or assembly, connect speakers to the outputs and turn the input volume control all the way down. Turn on all the tubes and turn the unit on.

Your B+ voltage should be between 250-275 vdc. The B+ voltage on your output tubes (pin 3) should be between 250-275 vdc.

If a 5Y3GT rectifier is used, the output tubes cathode resistor should be changed from 100 ohms to 150 ohms.

AC ripple can be measured on the outputs and should be less than 2 millivolts.

The silver/teflon wire is used to connect the output tubes cathode (pin 3) to the cathode resistor (100 ohm 25w), and should be run in equal lengths from each tube.

The outputs on this amp float with no reference to ground - do not connect the negative to ground or the chassis. If you do you won't be able to SERIES the outputs when bridging the amp for mono use.

This amp is built with a single point ground, located on one of the power transformer mounting bolts. The silver litz wire is used to carry the ground buss for the entire circuit. Do not use the chassis for ground.

For safety, be sure to use the ground on your power cord, connecting it to the single ground point as everything else.

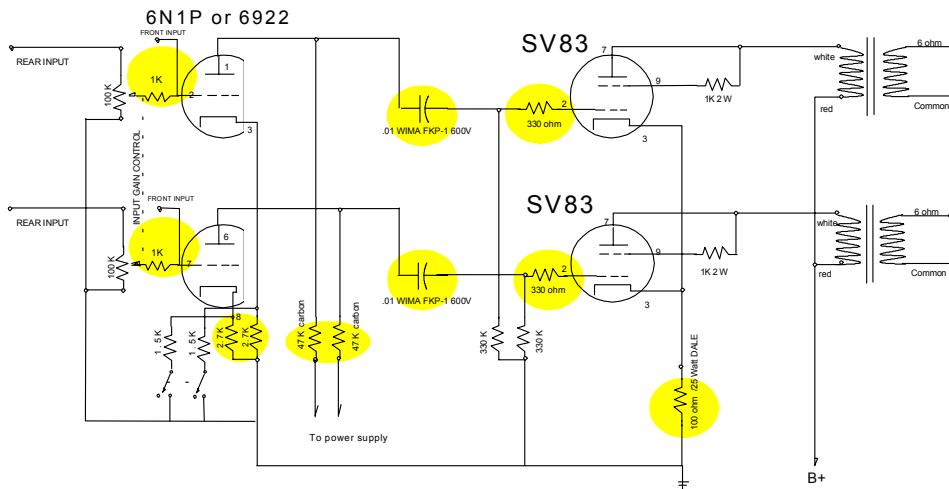

UPGRADED AREAS

The areas marked in yellow represent the upgraded parts between a stock SE84C and this SELECT model (SE84C-S)